

Modern Hydronics vs. Variable Refrigerant Flow Systems

Hydronics technology has long been known for providing unsurpassed heating comfort. It has also been used for cooling, primarily through chilled-water distribution systems in commercial and institutional buildings.

This well-established and highly successful track record is, in part, based on the physical properties of water that are relevant to the absorption of heat. It is also based on the versatility of water-based heat transport systems in adapting to a wide range of heat sources and heat emitters. *No other material provides comparable versatility, safety, reliability, energy efficiency or environmental compatibility.*

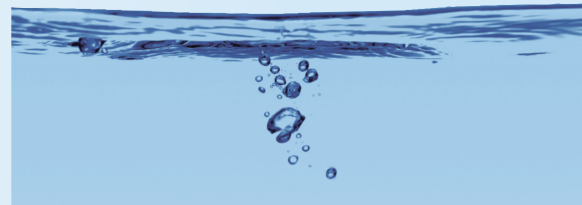

Over the last few years, a new method for moving thermal energy through buildings has appeared on the North American market. This approach uses refrigerant as the transport media throughout a building. It is known as either a Variable Refrigerant Flow (VRF) system or Variable Refrigerant Volume (VRV) system.

VRF systems use multiple interior heating/cooling terminal units that have a stream of refrigerant passing through them. The flow rate of the refrigerant through each terminal unit varies depending upon the current heating or cooling load that terminal unit is trying to satisfy.

This issue of **Water Works!** provides a comparison between hydronic distribution systems and VRF distribution systems. It discusses the fundamental differences in heat transport, safety, compatibility with future equipment and energy efficiency.

Figure 2a

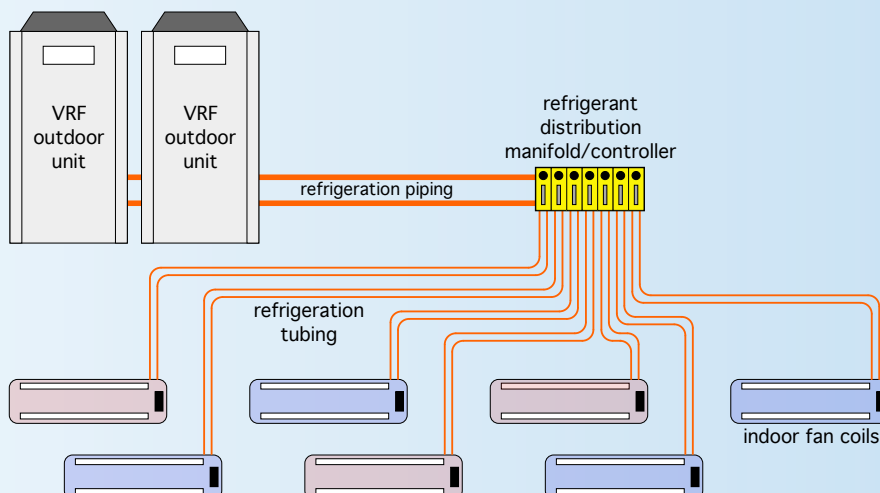

Figure 2b



Water vs. Air:

When comparing the ability of different fluids to convey thermal energy, the physical properties that are relevant are specific heat, density, and heat capacity.

The specific heat of a material is the amount of heat required to raise a unit weight of a material by one degree in temperature. In the IP unit system, one Btu is required to raise one pound of water by one degree Fahrenheit.

The density of a material is the weight of that material required to fill a unit volume. In the IP unit system, 62.4 pounds of water at a temperature of 60°F will fill a one-cubic-foot container.

The heat capacity of a material is the amount of heat required to raise a unit volume of that material by one degree. It can be found by multiplying the density of the material by its specific heat.

The heat capacity of materials such as liquids or gases that flow through a heating or cooling distribution system determines the size of the “conduits” through which those materials must be moved to deliver a given rate of transport. The higher the heat capacity of a material, the smaller the volume that must be moved through the distribution system within a given time, and the smaller the conduits through which this material can flow, all others conditions being the same.

A big difference:

The heat capacity of water is 62.4 Btu/ft³/°F.

The heat capacity of air is 0.018 Btu/ft³/°F.

Thus, a given volume of water can store $62.4/0.018 = 3,467$ times as much heat as the same volume of air. This is the “science” that allows water-based heating and cooling systems to use much smaller piping in comparison to the size of ducting required for the same rate of heat transfer.

Figure 3 shows a scaled comparison of two heat conveyance systems: a 14" by 8" duct, and a ¾"-size pipe. Both of these conduits were sized using industry standard practices and are intended to carry the same rate of heat transfer — about 60,000 Btu/hr.

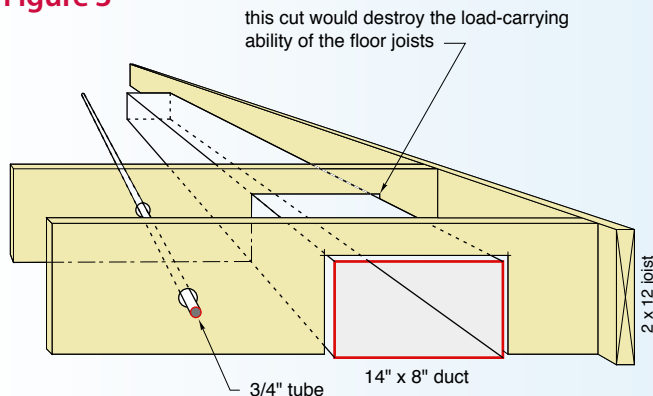
Figure 3

It is relatively easy to route a ¾" tube carrying water through a 1"-diameter hole near the mid-height of the 2x12 floor joists — especially if the tube is flexible. In contrast, trying to conceal a 14" x 8" duct within the floor framing would destroy its structural ability.

Total Energy Use:

The total energy required for heating or cooling a building can be divided into two components:

1. The energy required to generate the heat or to remove heat for cooling. This is called *thermal energy*.
2. The energy required to move that heat, or cooling effect, from where it's generated to where it's needed in the building. This is called *distribution energy*.

Heating and cooling systems move thermal energy from a mechanical room where it is generated to the locations in the building where it's needed. This is done by “loading” the thermal energy onto some type of transport material, moving that material from the mechanical room to the locations in the building where the thermal energy is needed, and then “unloading” the thermal energy from the transport media to the space being conditioned. After the thermal energy is unloaded from the transport media, that media returns to the mechanical room to be reloaded with thermal energy.

The distribution energy required to move thermal energy through a building is dependent on the choice of transport media, as well as how the system is designed.

The two more common transport media for distributing thermal energy within buildings are water and air. However, in VRF systems, refrigerant is circulated through the entire building in both liquid and vapor phases to move heat.

It can be shown that well-designed hydronic distribution systems can transport a given rate of thermal energy flow using approximately 10% of the distribution energy required for a forced-air distribution system that is delivering the same rate of heat transport.

This is largely the result of water having a heat capacity almost 3,500 times higher than that of air. It is also based on the resistance to flow characteristics of water through piping and air through ducting.

The distribution energy required to move refrigerant throughout a building is also relatively high in comparison to water. This is primarily due to the high flow velocity of vapor-phase refrigerant (approximately 4,000 feet per minute, or 66 feet per second). This high velocity is needed to properly entrain oil and return it to the compressor.

Figure 4 shows a comparison of the distribution energy required to move cooling effect through a building. It assumes that the thermal energy is produced by a compressor-driven vapor compression system (i.e., a heat pump). The vertical axis represents the percentage of the compressor power required to *move* the cooling effect generated by the refrigeration system. The horizontal axis represents the distance from the thermal energy source (e.g., chiller, outdoor unit, etc.) to the load.

Figure 4

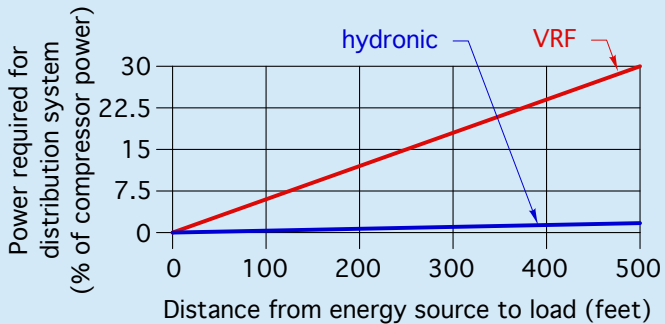

Data Source: Hydronics Industry Alliance

The VRF system uses a significantly higher percentage of the compressor power to move thermal energy through refrigeration tubing (about 6% per 100 ft. of refrigerant line set), compared to the hydronic system, which uses about 0.3 % per 100 ft. of distribution distance (e.g., 200 feet total piping circuit length).

Hydronic heating and cooling remain the best choice:

Although VRF systems are being aggressively marketed in North America, designers should not lose sight of the fundamentals that have allowed hydronic-based heating and cooling distribution systems to become the “gold standard” in commercial and institutional HVAC systems.

Here are several of those fundamentals to consider:

1. Hydronic systems can be used with many energy sources.

Hydronic heating and cooling systems are easily adaptable to a wide variety of current and future energy sources. Virtually any device or process that creates heated water is a potential hydronic heat source. These devices include boilers fueled by natural gas, propane or fuel oil; geothermal and air-to-water heat pumps; and renewable energy heat sources, such as solar thermal collectors and biomass boilers. Other potential heat sources include waste heat recovery, off-peak thermal storage systems, and combined heat and power (CHP) systems.

In some cases, two or more of these heat sources can be combined and share the heating or cooling load based on the most favorable operating conditions for each source. For

example, an electrically operated heat pump might be used to supply the load during night time hours when utility rates are reduced. Its output might then be supplemented or fully assumed by a gas-fired boiler during periods when utility rates are higher or at times when the heat pump cannot provide the required capacity.

Likewise, many options exist as sources of chilled water for hydronic-based cooling systems. These include chillers and heat pumps operating on standard vapor compression refrigeration cycles, as well as gas-fired absorption chillers, and even water drawn from large/deep lakes.

This type of flexibility is not possible with VRF systems, which are powered solely by electricity.

Figure 5

Energy sources using hydronics	Energy sources using VRF
Gas/propane-fired boiler(s)	Electricity
Oil-fired boiler(s)	
Electric boiler(s)	
Geothermal heat pump(s)	
Air-to-water heat pump(s)	
Absorption heat pump(s)	
Wood pellet/chip boiler(s)	
Solar thermal collectors	
Waste heat recovery	
Combinations of the above	
Electrically driven chiller	Electricity
Absorption chiller	
Deep lake water	

2. Hydronic systems allow for simpler future modifications.

When older commercial or institutional buildings are upgraded, their existing hydronic distribution system, or portions of that system, may be reusable in combination with a new central plant for producing heated and chilled water.

When VRF systems are used, the existing hydronic piping and all hydronic terminal units must either be decommissioned in place or removed from the building. All new copper piping and refrigerant-based terminal units must then be installed to each conditioned space. This can cause major disruption of interior finishes as seen in figure 6, and often requires normal activities in these spaces to be suspended during removal of old hardware and installation of new piping and terminal units.

Figure 6



3. Hydronic systems reduce risks associated with refrigerant leaks.

It's possible for a leak to develop in either a hydronic distribution system or a VRF system.

A leak in a hydronic distribution system is generally easy to detect, and the material leaking is just water or a mixture of water and antifreeze. Well-designed hydronic distribution systems provide numerous isolation valves that allow the portion of the system where the leak is to be isolated from the remaining parts of the system. The leak can then be repaired and water added to the system to bring it back online.

Larger VRF systems can contain hundreds of brazed joints on interior copper tubing. They can also contain many mechanical joints where the copper tubing attaches to distribution stations and individual air handlers. Figure 7 shows some examples of these joints.

Figure 7a

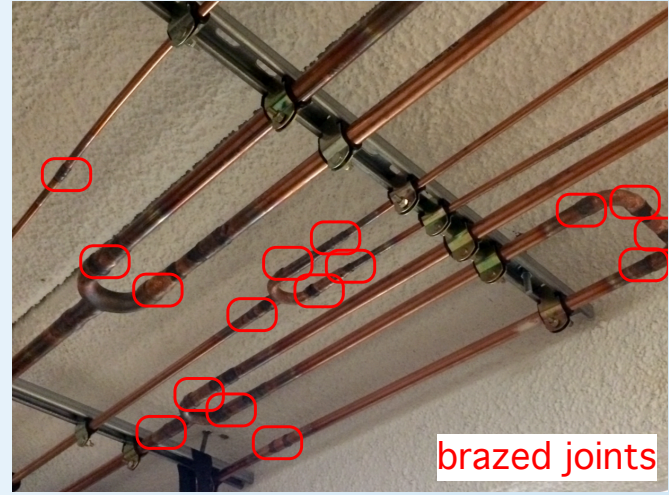
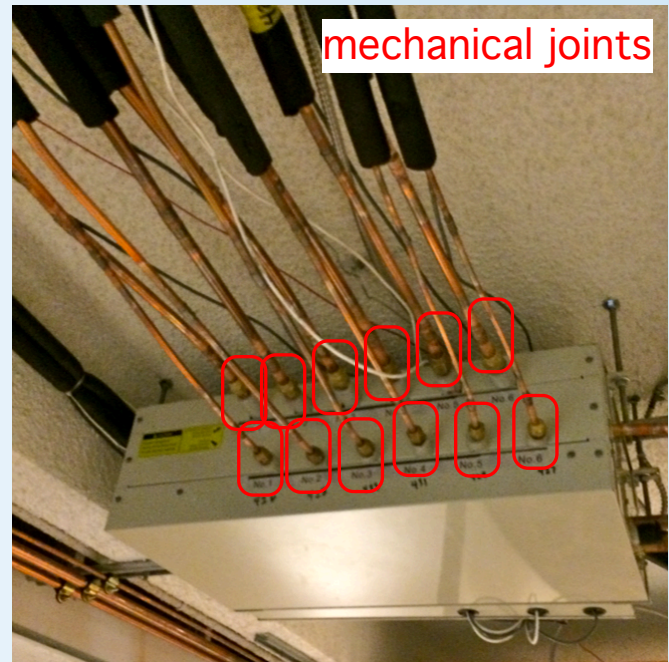

Figure 7b



Although the piping in a VRF system is pressure tested during installation, the possibility of a future leak increases along with the number of tubing joints in the system. Furthermore, the location of a refrigerant leak is not always easily detected. Specialized leak detectors have been developed for this purpose.

A leak in a VRF system is a serious and potentially dangerous matter. VRF systems contain much more refrigerant than a hydronic system served by a typical heat pump or direct expansion chiller. Under certain conditions, a single leak can be responsible for a complete loss of refrigerant from the system. Large refrigerant leaks can require immediate evacuation of the building and intervention by HAZMAT professionals.

Refrigerants such as commonly used R-410a are heavier than air. If a leak develops in the interior portion of a VRF system, the refrigerant could accumulate in the lower portions of rooms, with highest concentrations near the floor, and reduced concentrations higher in the room. Such accumulation will displace air in the room. In spaces with minimal, if any, ventilation, it is possible for refrigerant concentrations to reach values that could render occupants unconscious, and ultimately lead to suffocation.

ANSI/ASHRAE standards 15 and 34 define specific refrigerant concentration limits (RCLs) based on pounds of refrigerant per thousand cubic feet of interior volume, beyond which acute toxicity is expected. Those designing VRF systems should verify that the amount of refrigerant that could be lost due to a leak, and the smallest space into which this refrigerant could accumulate, are in compliance with this standard.

Figure 8

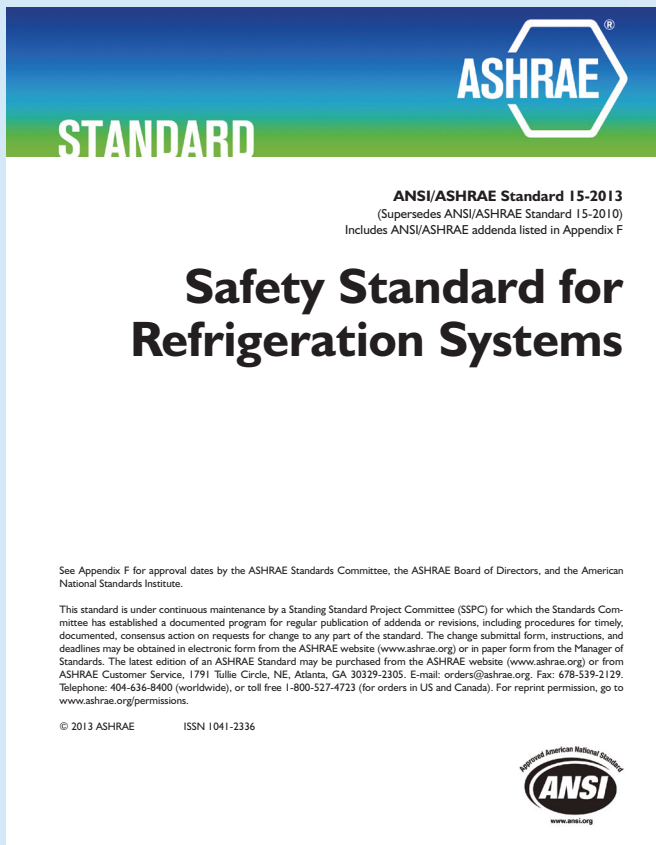

Courtesy of ASHRAE

Figure 9a shows the situation that must be assumed: Specifically, that the entire refrigerant charge in the VRF system could potentially leak into the smallest room served by that system.

Figure 9a

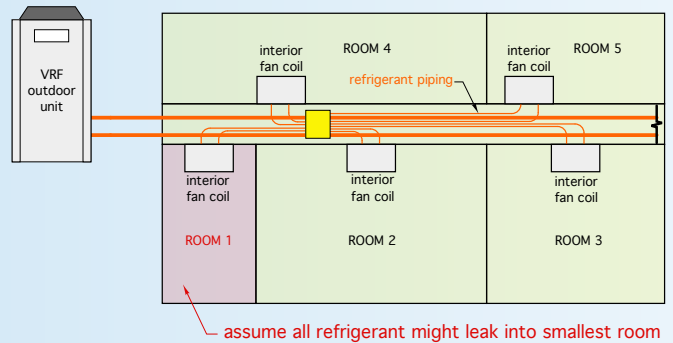

Figure 9b

Occupancy classification	Refrigerant Concentration Limit ** (lb/1000ft ³)	Room Height (ft)	Smallest room served (ft ³)				
			1-ton system	3-ton system	5-ton system	10-ton system	20-ton system
Non-institutional	26.0	9	19	58	96	192	385
Institutional	13.0	9	38	115	192	385	769

* Cuniff, G. (2013, December). *Applying Refrigerant Codes*, HPAC Engineering

** based on ANSI/ASHRAE Standard 34

Some heat pumps used in combination with hydronic distribution systems, such as the SpacePak Soltice SE and Soltice Extreme, keep all refrigerant outside the building they heat or cool. In the unlikely event of a leak, refrigerant would dissipate to the atmosphere and not pose a potential health or safety risk.

4. Hydronic systems use much less distribution energy.

Although proponents of VRF systems argue that no circulators are needed to move refrigerant throughout a building, electrical energy is still required just to move refrigerant gas and liquid through piping. That energy is supplied as electrical input to the system's compressor(s). The electrical energy consumption for moving refrigerant through a VRF system per unit of heat or cooling energy delivered is significantly higher than that required for a well-designed hydronic system (see Figure 4).

5. Hydronic distribution systems are not dependent on specific refrigerants.

Hydronic systems use water, or in some cases, a water-based solution of antifreeze. They are not subject to radical redesign or modification based on future changes in refrigerants.

Over the last two decades, highly successful refrigerants such as R-22 have been phased out of the North American market due to concerns over their effect on climate change. Replacement refrigerants have been developed. However, the properties of these replacement refrigerants have also mandated changes in components such as refrigerant piping and the oils that are carried throughout the system with the refrigerant.

Figure 10



While it's impossible to know what refrigerants will remain acceptable over the next 10 to 20 years, efforts continue toward improving the performance of all devices that use refrigeration cycles. Such effort could lead to breakthroughs that allow refrigerants such as carbon dioxide or ammonia to emerge as the new standards. This could eventually render "legacy" chillers or heat pumps that rely on present-day refrigerants obsolete. Piping that carries present-day refrigerants throughout a building may not be suitable for future refrigerants or their associated oils. Upgrading a legacy VRF system could thus require replacement of piping, terminal units or other hardware, as well as recycling of refrigerant and their associated oils. Such changes would be very costly.

6. Hydronic systems allow easy integration of thermal storage.

Many heating and cooling systems can benefit from thermal storage. The high heat capacity of water makes it an ideal thermal storage material for both heating and cooling systems. The heated or chilled water may be produced by heat pumps or chillers at times when "off-peak" electric utility rates are in effect, such as at night or on weekends.

Water-based thermal storage can also be used to eliminate short cycling of heat sources and chillers when the distribution system is highly zoned. It can also be incorporated into systems that have renewable energy heat sources, such as solar thermal collectors, air-to-water heat pumps or biomass-fuel boilers. Combined heat and power (CHP) systems also benefit from water-based thermal storage.

Thermal storage is easy to implement when a hydronic heating source and distribution system are used. In many systems, the water that stores thermal energy in a tank can eventually pass directly through the distribution system without need of any heat exchangers. This eliminates the cost and complexity of the heat exchanger(s), and the thermal penalty imposed by their use.

Figure 11 shows an example of how a thermal storage tank can be used in combination with an air-to-water heat pump system.

Figure 11

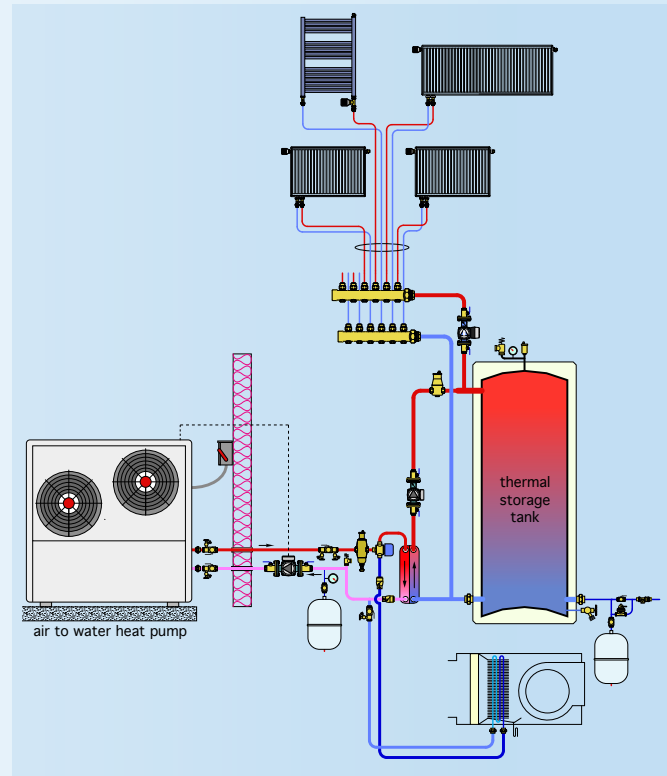

Thermal storage is not used with VRF systems.

7. A variety of piping options are available.

Many hydronic systems can make use of polymer-based piping materials such as PEX, PEX-AL-PEX and polypropylene. These piping products are less expensive and generally easier to install than the *all-copper* piping systems required with VRF systems.

Figure 12

Piping options in hydronic systems	Piping required in VRF systems
Copper	Copper
Black iron/steel	
Stainless steel	
PEX	
PEX-AL-PEX	
PERT	
Polypropylene (PP-R)	

8. Hydronic systems allow for radiant heating and cooling.

Radiant panel heating has long been recognized for providing unsurpassed thermal comfort. Hydronic-based radiant panel heating has been used around the world for over a century. Modern radiant panel systems use continuous circuits of PEX or other polymer-based tubing embedded in floors, walls and ceilings. Figure 13 shows an example of a heated wall.

Warm water from a variety of heat sources can be supplied to these panels. They create interior surface temperatures and air temperature profiles that are close to ideal for human thermal comfort. They operate silently with minimal air movement and deliver heat to spaces using a fraction of the distribution energy required for forced-air systems or VRF systems. Hydronic-based radiant panel heating also has a proven record of energy-saving performance in a wide variety of buildings, ranging from single family homes to large commercial garage facilities.

In contrast, VRF and VRV systems are limited to air as the final means of conveying heat from refrigerant into heated spaces. They are not well-suited to interior spaces with tall ceilings, or applications where internally generated dust, such as in a wood-working shop, would quickly clog their air filters.

9. Hydronic systems provide load flexibility.

Along with space heating and cooling, hydronic systems are easily expandable to provide high-capacity domestic water heating, as depicted in Figure 14, as well as snowmelting and pool heating. These ancillary loads can be prioritized to reduce the total thermal capacity needed.

Figure 13a



Figure 13b

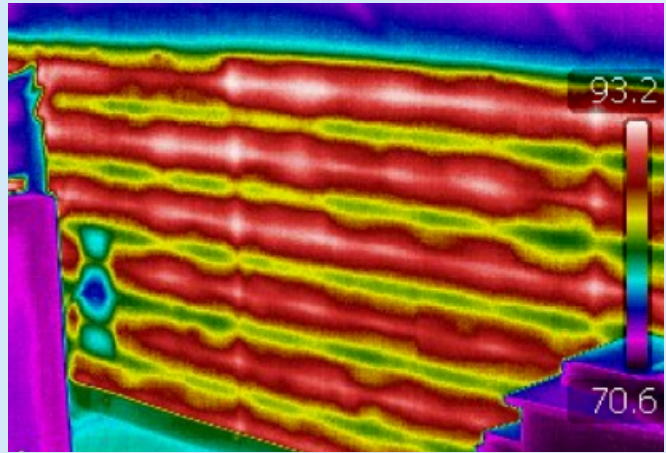

Figure 14

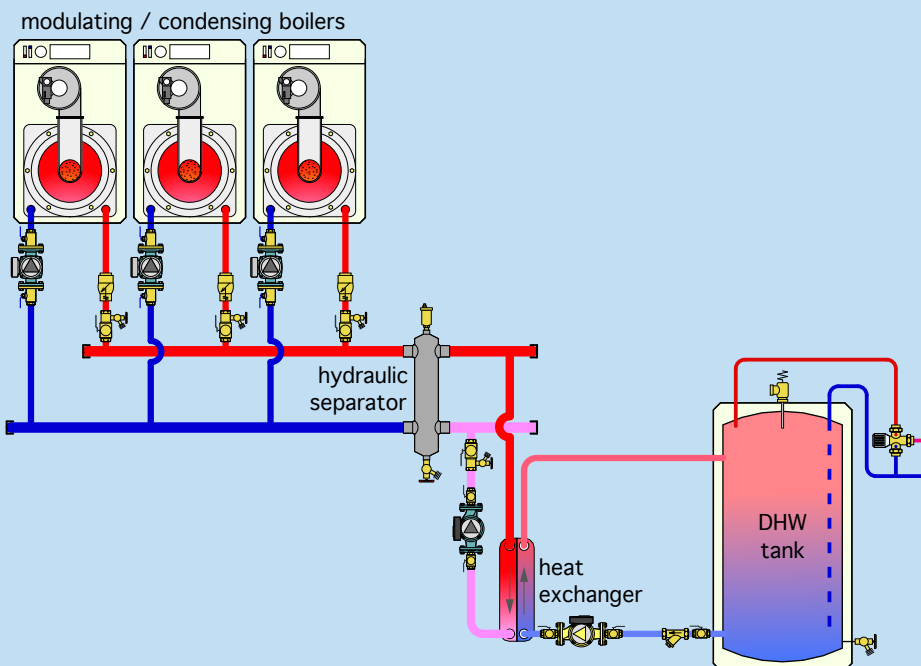

Figure 15



Source: simplepooltips.com, <http://simplepooltips.com/swimming-pool-pump-system-choosing-tips/>

Figure 16



Source: Infloor Heating Systems

10. Hydronic systems provide longer life expectancy.

A well-designed and properly maintained hydronic heating or cooling system is a long-term investment. Although the life of the original heat source or chiller is typically 15 to 25 years, the distribution system (e.g., the piping, valves, heat emitters and terminal units (cooling)) can usually provide many decades of service. Many hydronic systems that were installed over 50 years ago remain in operation today.

The ASHRAE 2015 Applications Handbook, chapter 37, lists the median service life of air-to-air heat pumps and similar refrigeration-based HVAC equipment using fixed-speed compressors and outdoor condenser units at 15 years. There is no listing specifically for VRF equipment because of its relatively new use in the North American market. However, due to the manner in which the compressors in some VRF systems are operated at higher speeds to maintain heating capacity under low outdoor air temperature conditions, it is possible that the median life of VRF systems will be less than that of heat pumps with fixed-speed compressors.

11. Hydronic distribution systems are widely available.

The piping, valves, circulators and terminal units required in most hydronic systems can be sourced from many companies with distribution networks across North America. This provides options when the system is initially designed and installed, as well as when maintenance or replacement parts are needed in the future.

Most VRF systems are manufactured in Asia, and many use proprietary components. The availability of these specialized components may be more limited, especially in emergency situations when they are needed quickly.

Most manufacturers of VRF systems require installation and maintenance by factory-trained technicians. These technicians often use specialized diagnostic equipment for troubleshooting. The rapid evolution of electronic controllers and firmware used in VRF systems underscores the need for readily available, trained technicians who can keep these systems operating and at competitive rates.

12. Hydronic systems allow for heat metering.

In hydronic systems, an accurate measurement of flow rate and temperature drop (from supply to return) allows for a simple calculation of the rate of heat transfer. The total thermal energy that passes a specific point in the system can also be determined by integrating these measurements over time. Several companies now offer "heat-metering" hardware (see Figure 17), which can be easily installed in a wide range of hydronic heating and cooling systems. Heat-metered systems allow owners of multi-tenant buildings to know what each tenant's thermal energy use was, and to invoice them accordingly. Such systems can centralize heat production and chilled-water production, which provides many technical and economic benefits.

Figure 17a



Courtesy of ISTEC

Figure 17b

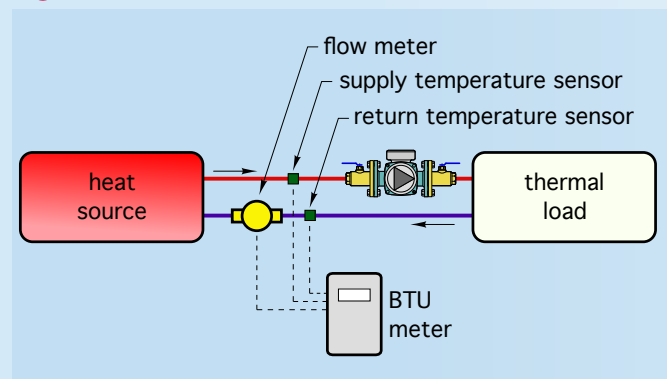

Heat metering is not currently available in VRF systems.

13. Hydronic systems allows for district energy distribution systems.

The availability of cost-effective heat-metering equipment for hydronic systems, in combination with advances in insulated underground piping and variable-speed pumping, sets the stage for increased use of district energy systems in North America. Such systems use a central plant to produce hot water for heating and chilled water for cooling. They allow the possibility of eliminating heating or cooling generation equipment within each building served by the district system. The centralized generation of heating and cooling energy allows for economies of scale, better capacity control and higher degrees of reliability compared to having a heating/cooling system in each building. The size of these systems can vary from a few buildings to systems that span many city blocks and contain miles of piping. Such systems are not possible using currently available VRF hardware.

Figure 18

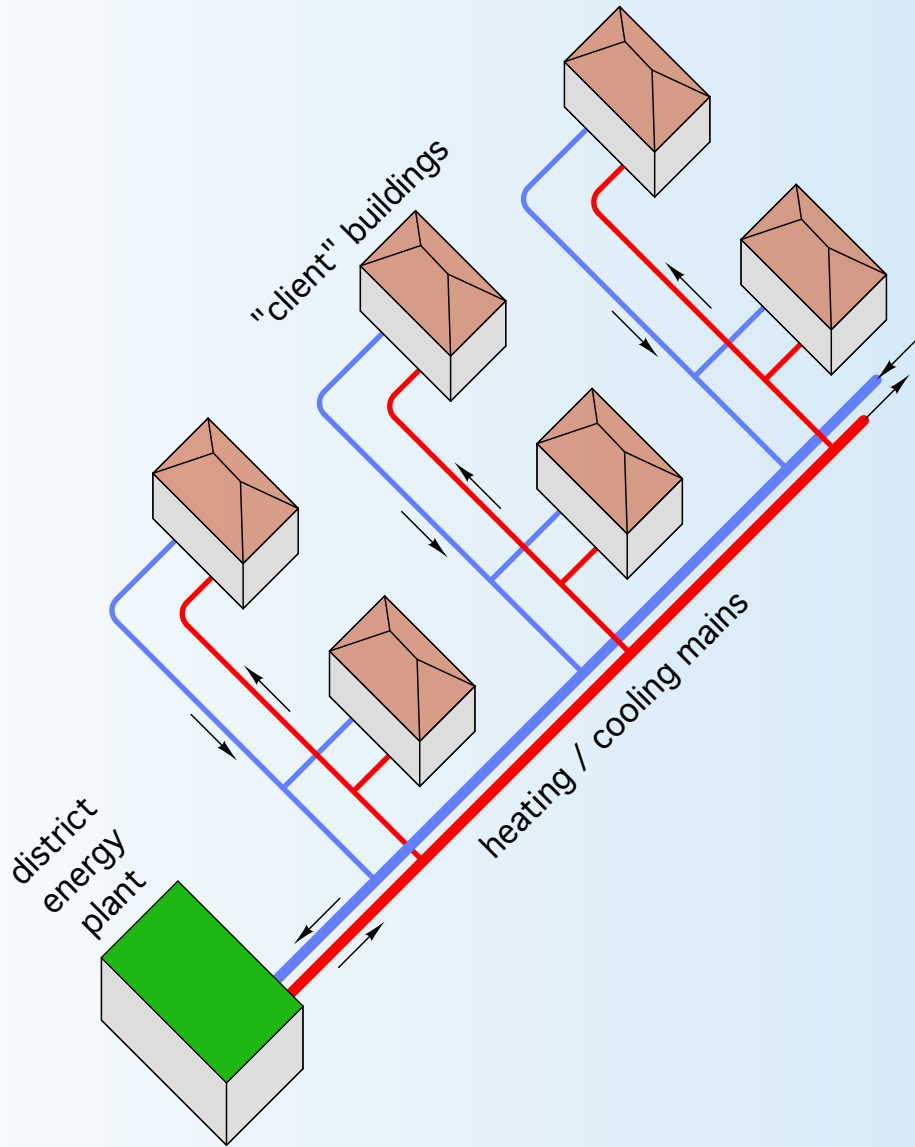

Summary

Hydronic distribution systems for heating and cooling buildings are a tried-and-true technology. They leverage the natural advantage of water as a heat-transfer medium. When properly planned and installed, the piping components used in hydronic systems can last for many decades, often beyond the life of the initial heat source or chiller. Hydronic systems offer unmatched versatility when it comes to matching the system to the exact load requirements of the building. The hardware for most hydronic systems can be sourced from a wide variety of vendors and installed by local HVAC professionals. Water, and not refrigerant, remains the superior choice when it comes to efficient, reliable and safe heating and cooling systems for buildings.



SPACE PAK 
HYDRONICS

www.spacepak.com